

LUXIMA™ LUX1310 Evaluation System

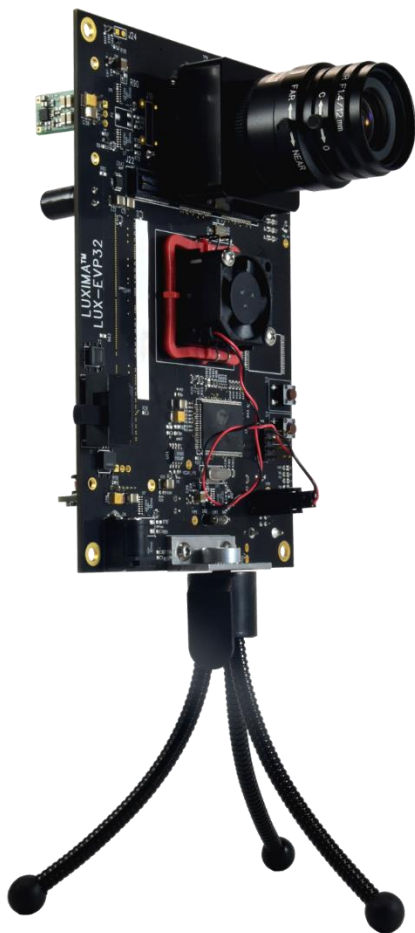

1280 × 1024 @ 1,000+ FPS Sensor Evaluation System

The LUX1310-EVS enables the user to evaluate the performance of the LUX1310 Sensor. The LUX1310 Sensor is a Global Shutter CMOS Digital Sensor with 1.3 Megapixel (1280 × 1024) @ 1,070 FPS. The LUX1310-EVS consists of the LUX1310-SEP, a Sensor Evaluation Platform, and the LUX1310-SHB, a Sensor Headboard.

Main features of LUX1310-SHB

- Ultra-small 38.1mm × 38.1mm Sensor Headboard footprint
- 1280 × 1024 pixels @ 1,070 FPS 2/3" Global Shutter CMOS Sensor
- On-board drivers for buffering reference voltages to the LUX1310 Sensor
- Two small connectors for data output, register programming and voltage references
- Lens mount support CS-mount and C-mount lenses with CS to C mount adapter
- 2/3" C-mount lens for the Sensor Headboard included

Main features of LUX1310-SEP

- On-board FPGA to receive 16-channel LVDS data @ 1Gbps/channel
- 2GB DDR3 memory to store consecutive image frames from the LUX1310-SHB
- On-board USB chipset for USB 2.0 interface to PC
- Sensor control software for image capture, playback and sensor communication
- USB cable and DC 5V power supply included

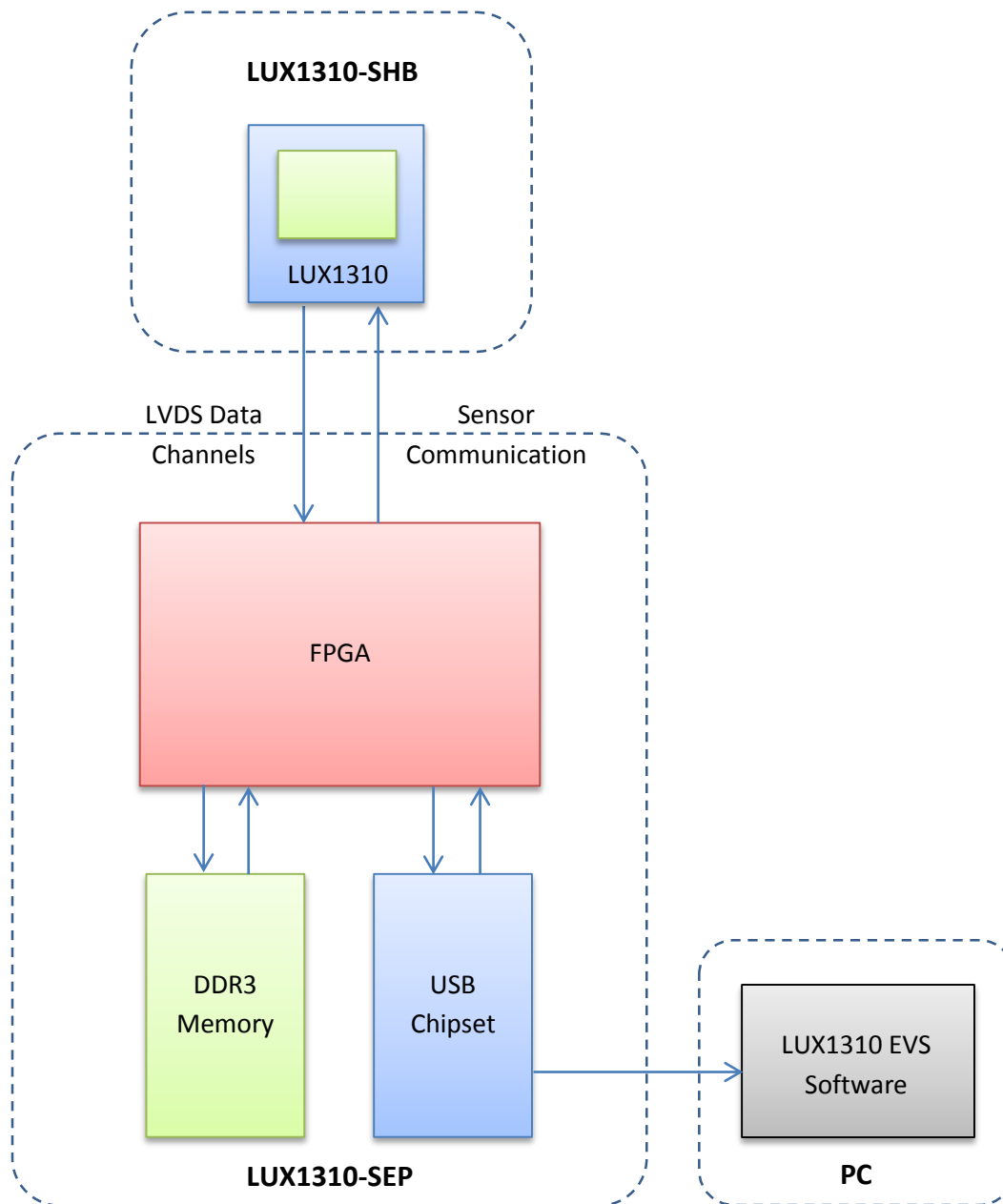

Documentation provided with purchase of Evaluation System

- Schematic of Sensor Evaluation Platform, LUX1310-SEP
- Schematic of Sensor Headboard, LUX1310-SHB
- Example artwork of Sensor Headboard layout
- Verilog code for receiving of LVDS data and deserialization
 - sensor_rx module shown in block diagram below

